

# SNES series

Ø130mm Explosion Proof Warning/ Signal Lights with Siren Buzzer

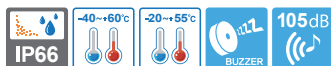

## Siren buzzer sound output of Max 105dB



SNESLR



SNESL

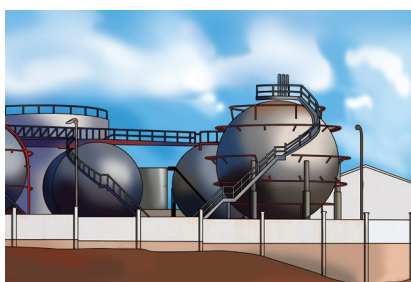

Flameproof warning/ signal lights applied in an areas where potentially explosive materials may linger as shown in the refinery image above.



### Common Specifications(SNESLR/ SNESL/ SNES-S/ SNES)

- Light weight and compact explosion proof warning lights with a siren buzzer
- A variety of light source selections from bulb, LED, and xenon lamp
- Aluminum housing provides excellent durability
- Fully enclosed structure with protection rating of IP66
- Integrated housing and terminal box model
- Sound type and sound volume : Siren buzzer- Max 105dB at 1m/ 7 sounds buzzer, Max 95dB at 1m
- User selected built-in buzzer with 7 sound patterns available upon request
- Housing standard color : MUNSELL No. 7.5BG 7/2
- Cable entry : 1/2" NPT
- Materials : Lens-Tempered glass, Inner lens-PC, housing-Al, Protection cage-ST316L, Reflector for LED type-PC/ Reflector for bulb type-Heat resistant ABS
- Certificates : IECEx, ATEX, NEPSI, KCs, CCS, CCC(F), TIIS
- Protection rating :
  - IECEx, TIIS - Ex d IIC T6 Gb, IP66
  - ATEX - II2G Ex d IIC T6, IP66
  - KCs - Ex d IIB+H2 T6
  - NEPSI - Ex d IIC T6, IP66
- Ambient operating temperature :  $-40^{\circ}\text{C} \leq T_{\text{amb}} \leq +60^{\circ}\text{C}$   
 $-20^{\circ}\text{C} \leq T_{\text{amb}} \leq +55^{\circ}\text{C}$  (TIIS)



### SNESLR LED Revolving Warning Light with Siren Buzzer

- Excellent omni-directional visibility with LED light collecting system and special multifaceted reflector
- Revolving speed : 120-140RPM

Model number	Voltage	Current	Sound pattern/ dB	Certificates	Weight	Color
SNESLR	DC12V	0.485A	• Warning sound(Buzzer) : 105dB • 7 sounds(Buzzer): 95dB		3.60kg	• R-Red • A-Amber • G-Green • B-Blue
	DC24V	0.411A			3.60kg	
	AC110V	0.111A			4.30kg	
	AC220V	0.055A			4.30kg	



### SNESL LED Steady/ Flashing Signal Light with Siren Buzzer

- Long-lasting high intensity LED light source
- Suitable for applications where bulb replacement is hard
- Built in switch for steady/flashing selection
- Flashing rate : 60-80 flashes/min

Model number	Voltage	Current	Sound pattern/ dB	Certificates	Weight	Color
SNESL	DC12V	0.432A	• Warning sound(Buzzer) : 105dB • 7 sounds(Buzzer): 95dB		3.65kg	• R-Red • A-Amber • G-Green • B-Blue
	DC24V	0.377A			3.65kg	
	AC110V	0.111A			4.30kg	
	AC220V	0.055A			4.30kg	



### Customization

- Explosion proof cable gland attached type available (Standard type does not come with explosion proof cable gland)
- Customized 2 way cable entries
- Customized cable entry (M20×1.5) available
- ATEX certified type
- IECEx certified type
- Customized built-in buzzer type with 7 sound patterns available

# SNES series

Ø130mm Explosion Proof Warning/ Signal Lights with Siren Buzzer

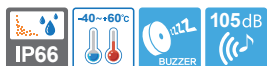

Siren buzzer sound output of Max 105dB



SNES-S

## SNES-S Xenon Strobe Signal Light with Siren Buzzer

- Lamp connector fastening structure allows for convenient lamp replacement
- Excellent long-distance visibility with strong flashing signal diffusion
- Flashing rate : 60-80 flashes/min

Model number	Voltage	Current	Bulb			Sound pattern/dB	Certificates	Weight	Color
			Spec	Standard	Parts no				
SNES-S	DC12V	0.655A	200V -550V	EUB0641 -1A(G) U Type	48	<ul style="list-style-type: none"> <li>• Warning sounds(Buzzer) : 105dB</li> <li>• 7 sounds(Buzzer) : 95dB</li> </ul>		3.60kg	<ul style="list-style-type: none"> <li>• R-Red</li> <li>• A-Amber</li> <li>• G-Green</li> <li>• B-Blue</li> </ul>
	DC24V	0.500A						3.60kg	
	AC110V	0.104A						4.25kg	
	AC220V	0.066A						4.25kg	

## SNES Bulb Revolving Warning Light

- Excellent signal light diffusion effect with multi-faced reflector
- Revolving speed : 120-140RPM

Model number	Voltage	Current	Bulb			Sound pattern/dB	Certificates	Weight	Color
			Spec	Standard	Parts no				
SNES	DC12V	1.766A	12V15W	G23 15S	17	<ul style="list-style-type: none"> <li>• Warning sounds(Buzzer) : 105dB</li> <li>• 7 sounds(Buzzer) : 95dB</li> </ul>		3.70kg	<ul style="list-style-type: none"> <li>• R-Red</li> <li>• A-Amber</li> <li>• G-Green</li> <li>• B-Blue</li> </ul>
	DC24V	1.044A	24V15W	G23 15S	18			3.70kg	
	AC110V	0.288A	12V15W	G23 15S	17			4.40kg	
	AC220V	0.144A	12V15W	G23 15S	17			4.40kg	



### Technical Diagram

(Units : mm)



SNES

SNESLR/ SNESL/ SNES-S/ SNES

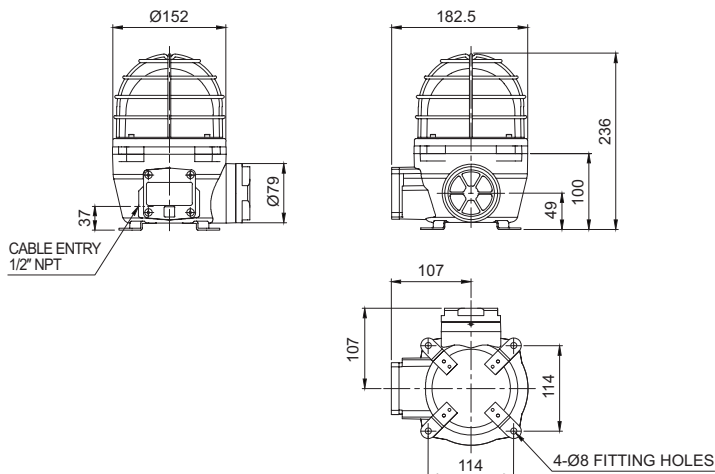

### Ordering Specification

<b>SNES</b>	-	<b>220</b>	-	<b>R</b>
[Model number]		[Voltage]		[Color]
<ul style="list-style-type: none"> <li>• SNESLR</li> <li>• SNESL</li> <li>• SNES-S</li> <li>• SNES</li> </ul>		<ul style="list-style-type: none"> <li>• 12-DC12V</li> <li>• 24-DC24V</li> <li>• 110-AC110V</li> <li>• 220-AC220V</li> </ul>		<ul style="list-style-type: none"> <li>• R-Red</li> <li>• A-Amber</li> <li>• G-Green</li> <li>• B-Blue</li> </ul>

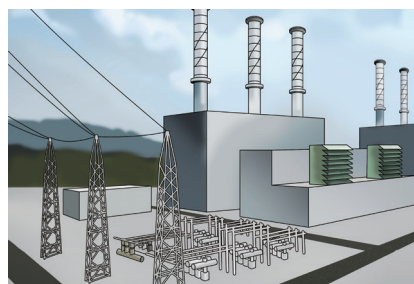

Flameproof warning/ signal lights applied in dust explosion areas such as coal dust shown in thermoelectric power plant image above.